

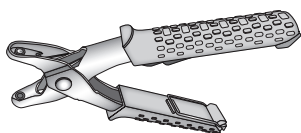

INSTRUCTIONS

INSTRUCCIONES / ANWEISUNGEN



GB Pliers

FR Pince

ES Tenazas

DE Zange

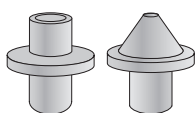

GB Hole Cutting Tool **FR** Outils à percer

ES Herramientas para perforar

DE Lochwerkzeug



GB Tool Remover

FR Enlever les outils

ES Quite las herramientas

DE Werkzeugentferner

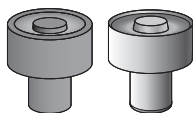

435 Series: 4mm (5/32")

GB Eyelets

FR Œillets

ES Ojetes

DE Ösen

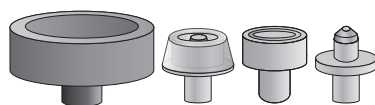

407 - B Series: 15mm (5/8")

GB Anorak/Jacket Snaps **FR** Boutons-pression Anorak

ES Broches a Presión Anoraks y Chaquetas **DE** Anorak Druckknöpfe

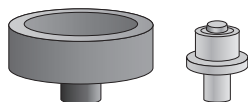

405 - C Series: 15mm (5/8")

GB Heavy Duty Snaps

FR Boutons-pression

ES Broches a Presión

DE Druckknöpfe

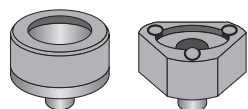

440 & 445 - A Series: 11mm (1/2")

GB Solid & Ring Top Fashion Snaps

FR Boutons-pression - Couleur unie & Vêtements légers

ES Broches a Presión - Tapa Superior & Anillo Superior

DE Mode Druckknöpfe - Einfarbig & Jersey

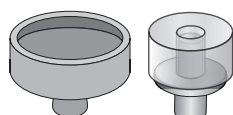

443 Series: 12.4mm (1/2")

GB Plastic Snaps **FR** Boutons-pression en plastique

ES Broches de Broches de Plástico **DE** Kunststoff-Druckknöpfe

⚠ Choking Hazard: Small parts. Keep away from children under 3 years. Always test on scrap fabric first.

⚠ Risque d'étouffement : Petites pièces. Tenir hors de portée des enfants de moins de 3 ans. Toujours tester d'abord sur une chute de tissu.

⚠ Peligro de asfixia: Piezas pequeñas. Mantener fuera del alcance de los niños menores de 3 años. Pruébalo siempre primero en retazos de tela.

⚠ Verschluckgefahr: Kleine Teile. Von Kindern unter 3 Jahren fernhalten. Immer zuerst auf Stoffresten testen.

Video



CLICK

Sew
GROUP

GROVES

DISTRIFIL

OX9 3FU
sales@groves-banks.com
www.grovesitd.co.uk

Z.1 Route de Châteauroux
36320 VILLEDIEU-SUR-INDRE,
France.

f/grovesitd @grovesitd
y/grovesofthame

product@distrifil.fr
www.distrifil.com

Hemline
www.hemline.com

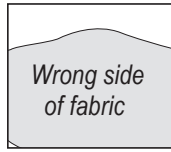
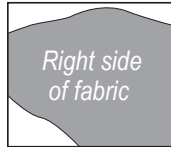
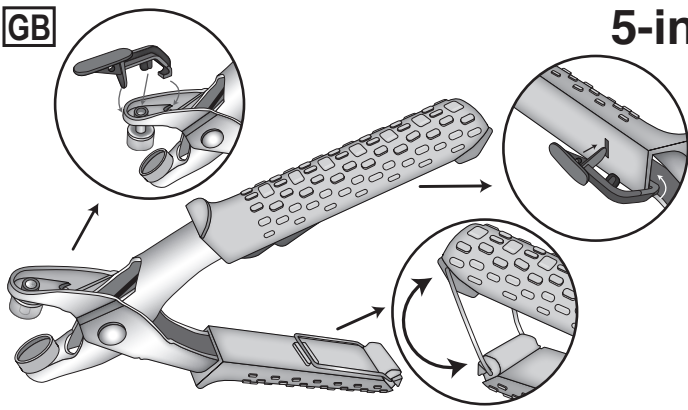

Cut **4mm** holes for 435 Series: 4mm (5/32") Eyelets

Cut **4mm** holes for 405 - C Series: 15mm (5/8") Heavy Duty Snaps

Cut **3mm** holes for 407 - B Series: 15mm (5/8") Anorak/Jacket Snaps

Hole Punchers

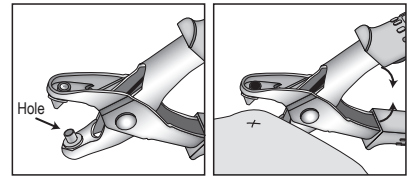
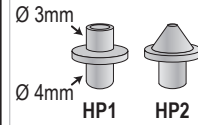

435 Series: 4mm (5/32") Eyelets

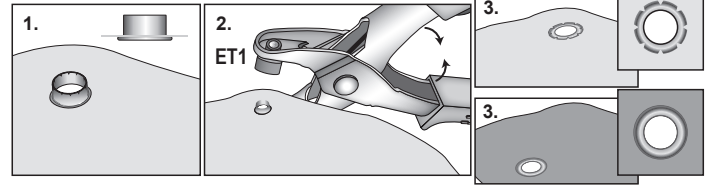
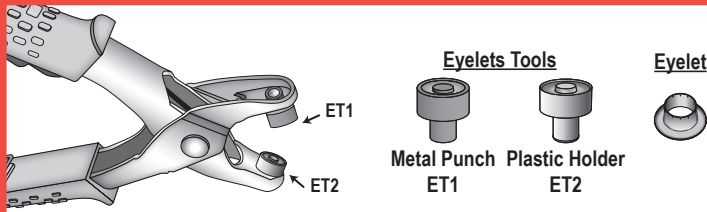

407 - B Series: 15mm (5/8") Anorak/Jacket Snaps

Anorak/Jacket Snaps Tools

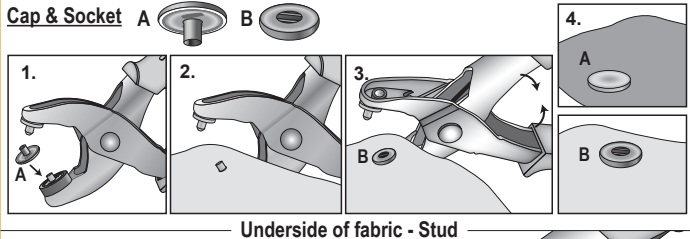
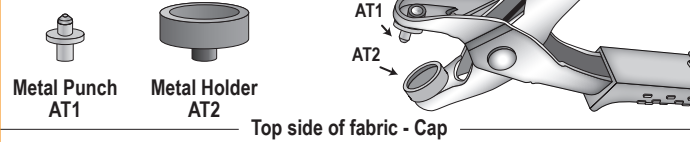

Anorak/Jacket Snaps Tools

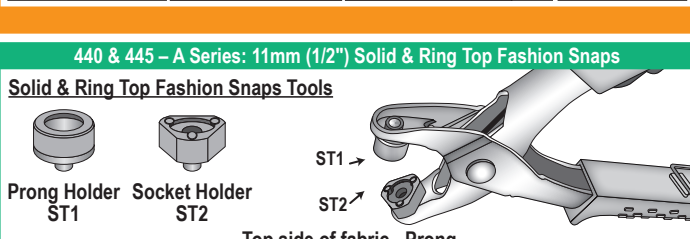
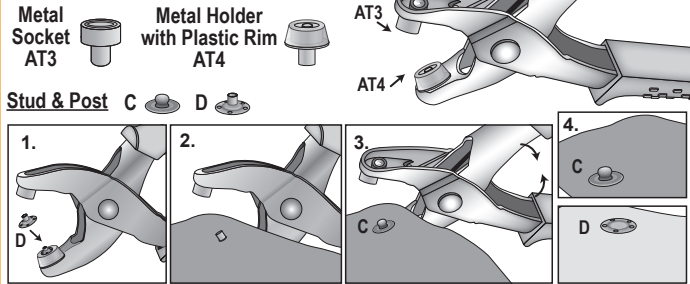

405 - C Series: 15mm (5/8") Heavy Duty Snaps

Heavy Duty Snaps Tools

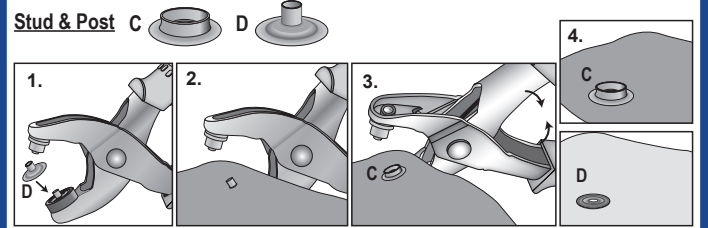
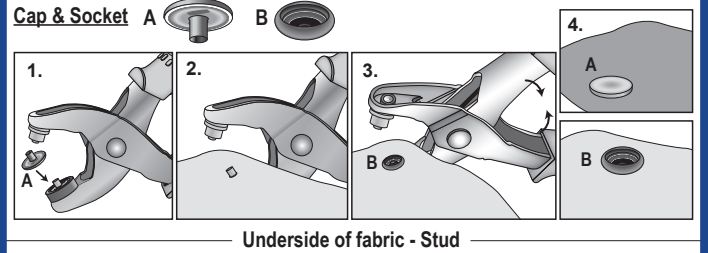
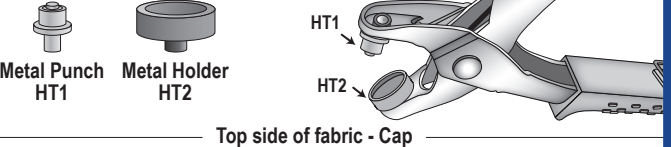

443 series: 12.4mm (1/2") Plastic Snaps

Plastic Snaps Tools

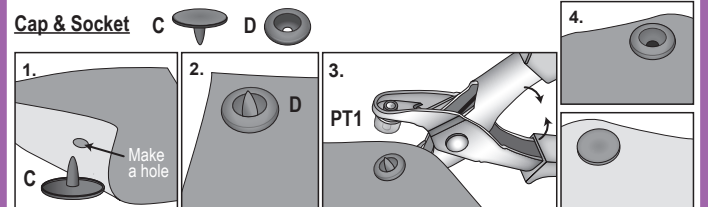
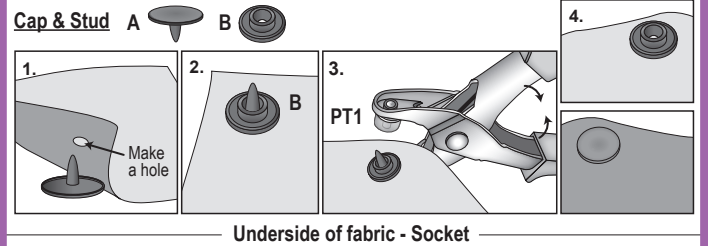
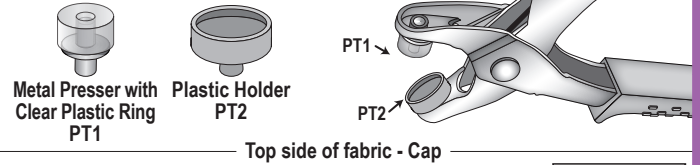

440 & 445 - A Series: 11mm (1/2") Solid & Ring Top Fashion Snaps

Solid & Ring Top Fashion Snaps Tools

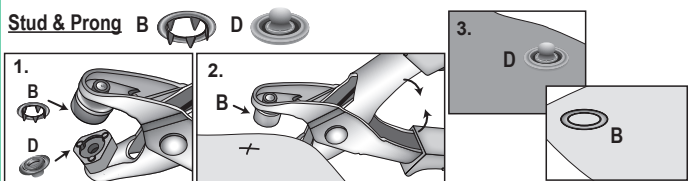
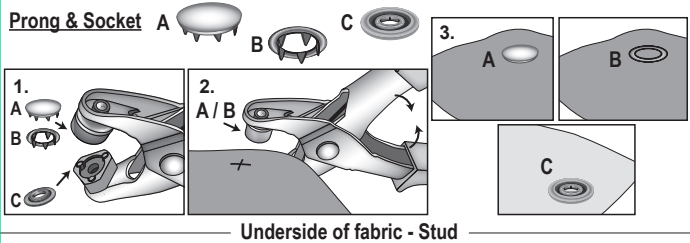
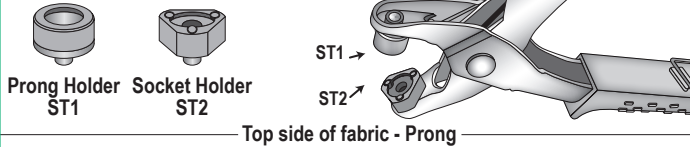

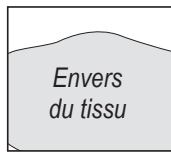
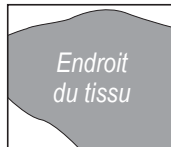
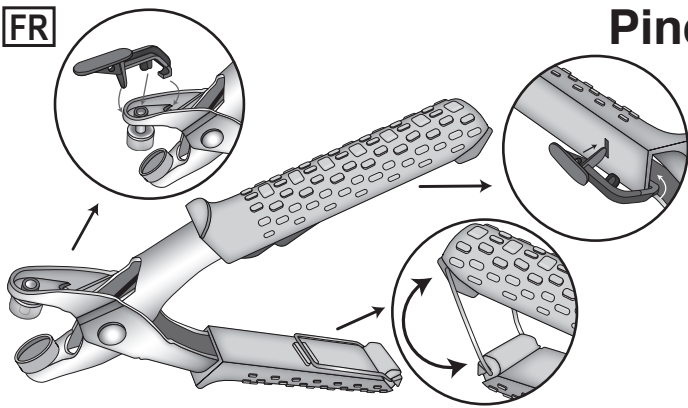

Coupez des trous de **4mm** pour la série 435: œillets de 4mm (5/32")

Coupez des trous de **4mm** pour la série 405 - C: Boutons-pression 15mm (5/8")

Découpez des trous de **3mm** pour la série 407 - B: 15mm (5/8") Anorak/Jacket Snaps

Perforateurs

Ø 3mm

Ø 4mm

HP1

HP2

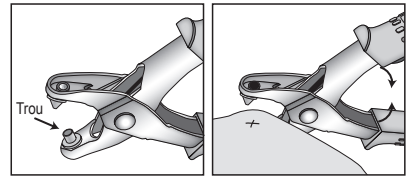

Série 435: Œillets de 4mm (5/32")

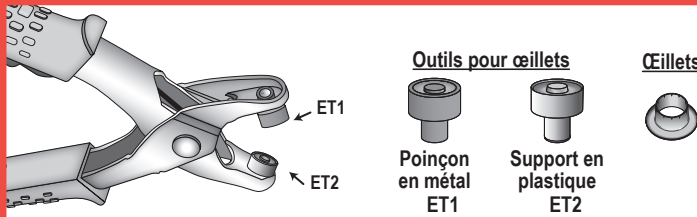

Outils pour œillets

Œillets

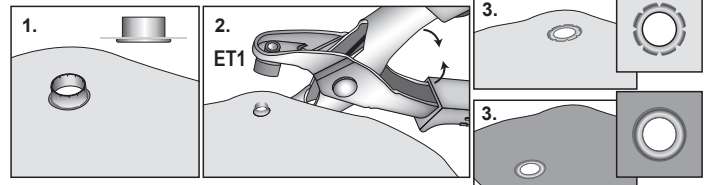
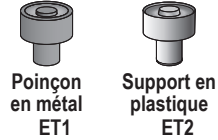

407 - Série B: 15mm (5/8") Boutons-pression Anorak

Outils de pose pour Anorak/Vestes

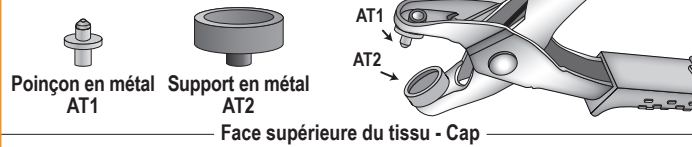

Face supérieure du tissu - Cap

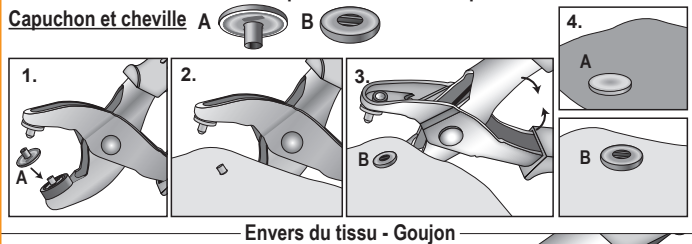

Envers du tissu - Goujon

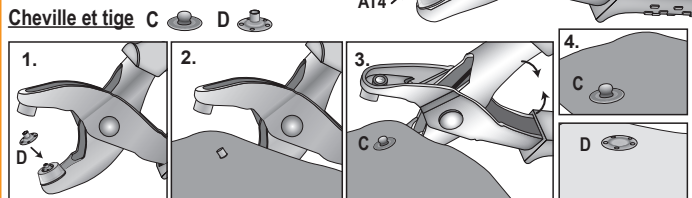
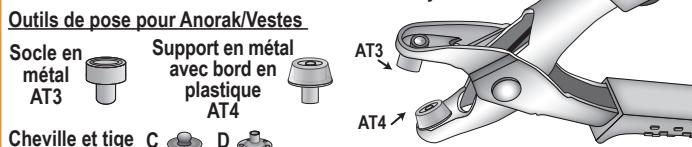

440 & 445 - Série A: 11mm (1/2") Boutons-pression - Couleur unie & Vêtements légers

Outils à boutons-pression solides et à anneaux



Face supérieure de l'étoffe - Pince

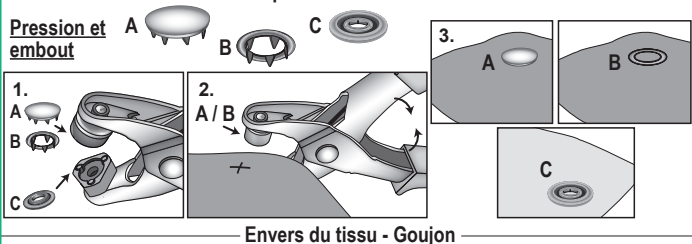

Envers du tissu - Goujon

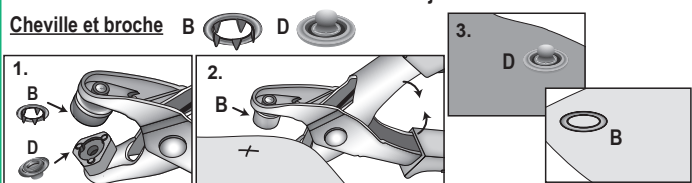

Cheville et broche

405 - Série C: 15mm (5/8") Boutons-pression

Outils de pose pour boutons à usage intensif

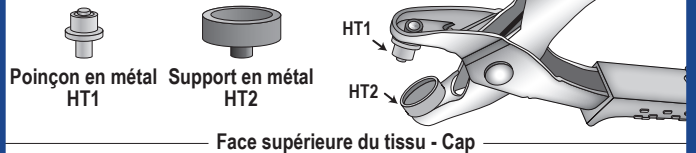

Face supérieure du tissu - Cap

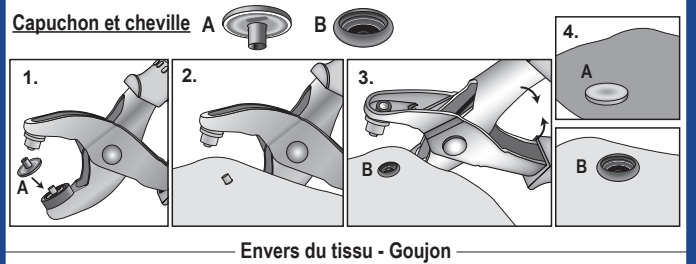

Envers du tissu - Goujon

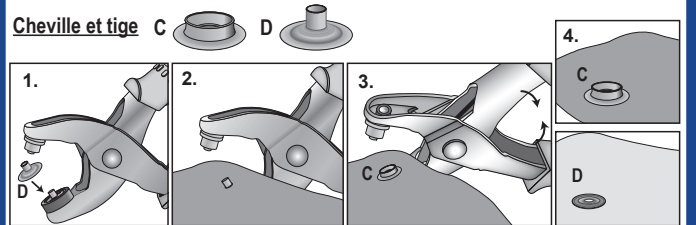

Cheville et tige

Série 443: 12,4mm (1/2") Boutons-pression en plastique

Outils pour boutons-pression en plastique

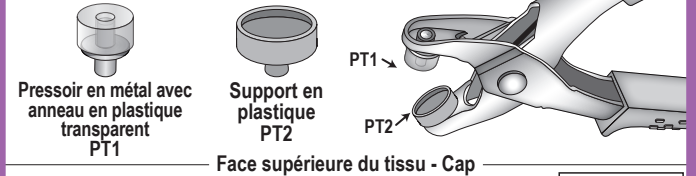

Face supérieure du tissu - Cap

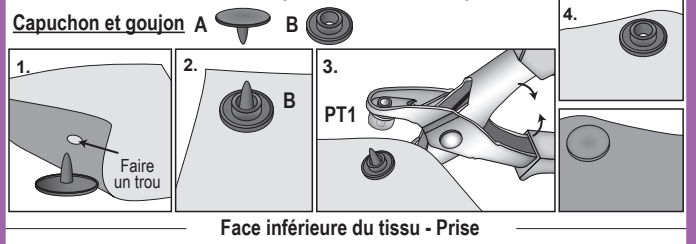

Face inférieure du tissu - Prise

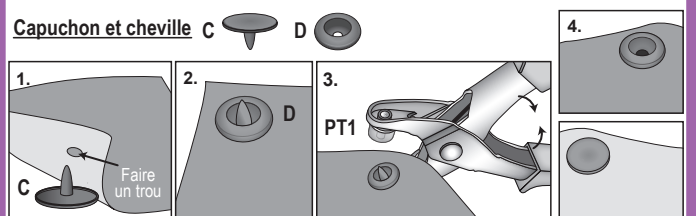

Cheville et broche

Tenazas 5 en 1

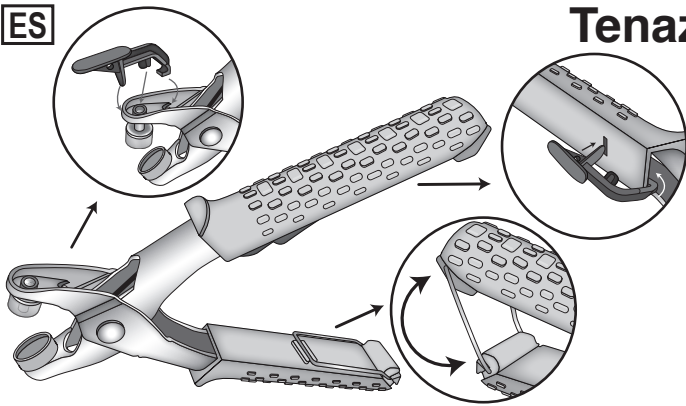

Corte orificios de 4mm para la serie 435: Ojales de 4mm (5/32")

Corte agujeros de 4mm para 405 - Serie C: Broches de 15mm (5/8") de alta resistencia

Cortar agujeros de 3mm para 407 - Serie B: Broches de anorak/chaqueta de 15mm (5/8")

Perforadoras

Ø 3mm

Ø 4mm

HP1

HP2

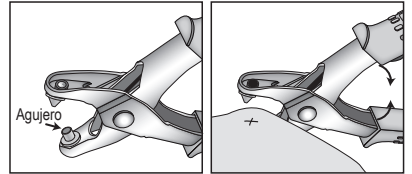

Serie 435: 4mm (5/32") Ojales

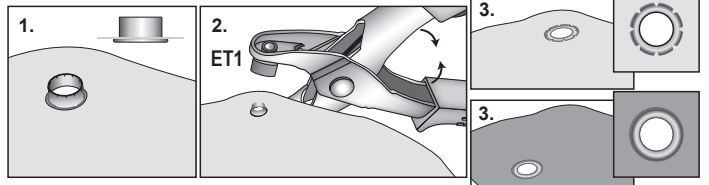
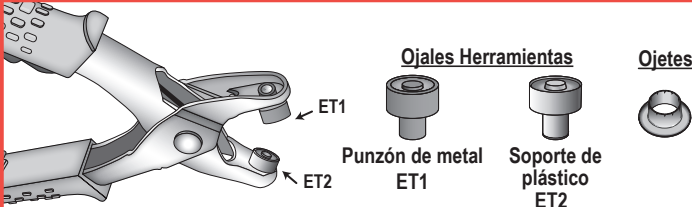

407 - Serie B: 15mm (5/8") Broches a Presión Anoraks y Chaquetas

Anorak/Jacket Snaps Herramientas

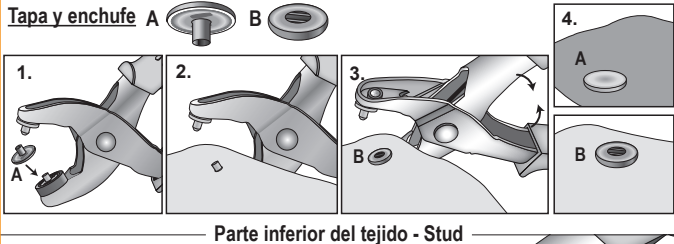

Anorak/Jacket Snaps Herramientas

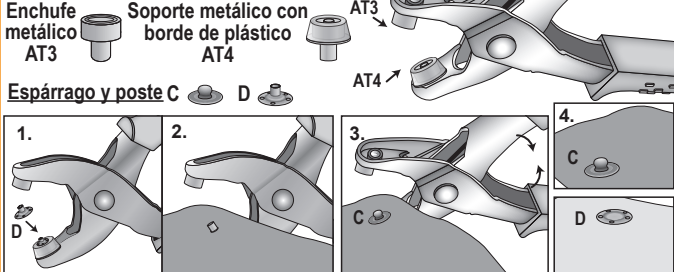

405 - Serie C: 15mm (5/8") Broches a Presión

Herramientas para broches resistentes

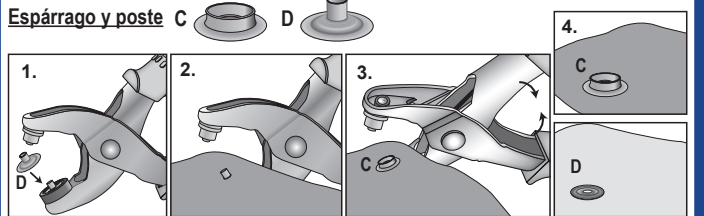
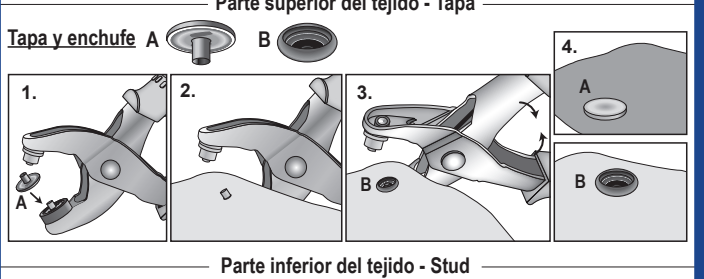

440 & 445 - Serie A: 11mm (1/2") Broches a Presión - Tapa Superior & Anillo Superior

Herramientas para broches de presión sólidos y de anilla

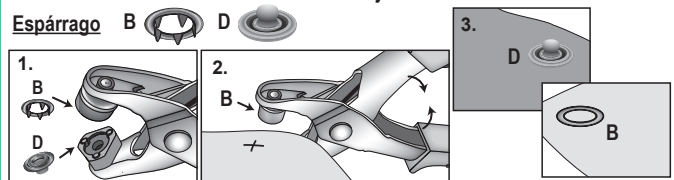
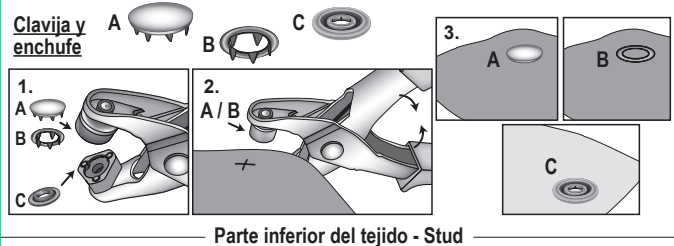
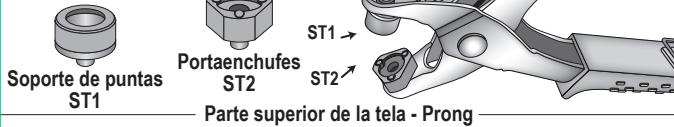

Serie 443: 12,4mm (1/2") Broches de Broches de Plástico

Herramientas para broches de plástico

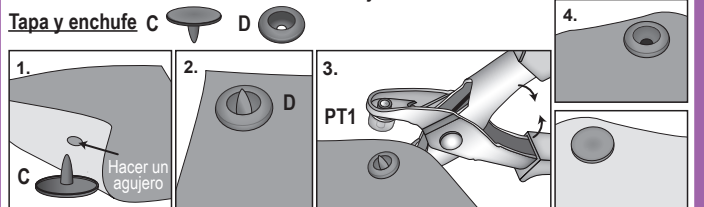
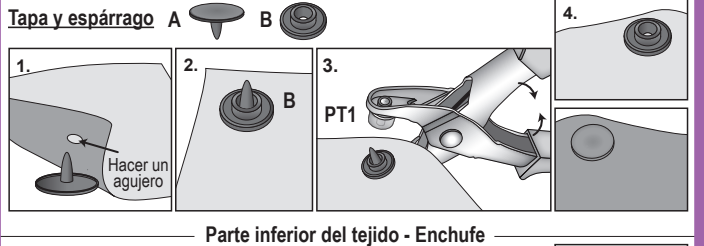

5-in-1-Zange

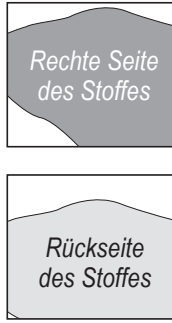
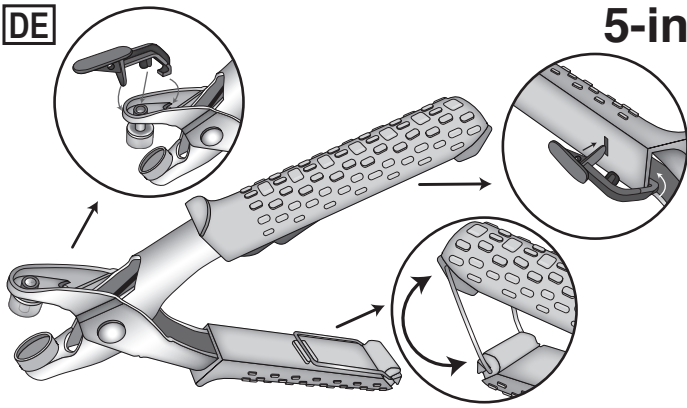

Schneiden Sie **4mm** Löcher für die Serie 435: 4mm (5/32") Ösen

Schneiden Sie **4mm** Löcher für die Serie 405 - C: 15mm (5/8") Heavy Duty Druckknöpfe

Schneiden Sie **8mm** Löcher für die Serie 407 - B: 15mm (5/8") Anorak/Jacke Druckknöpfe

Lochstanze

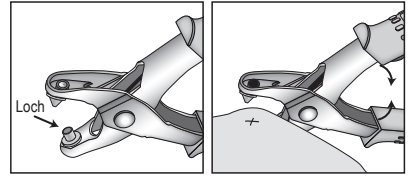
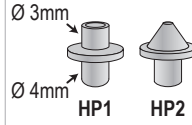

Serie 435: 4mm (5/32") Ösen

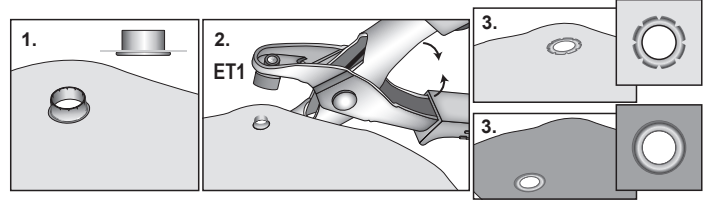
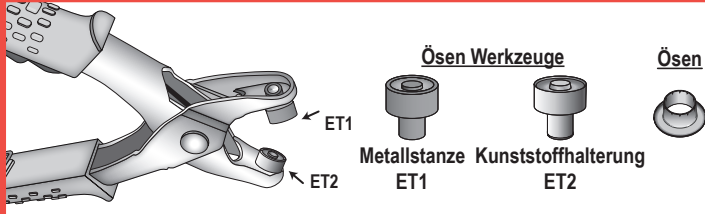

407 - Serie B: 15mm (5/8") Anorak Druckknöpfe

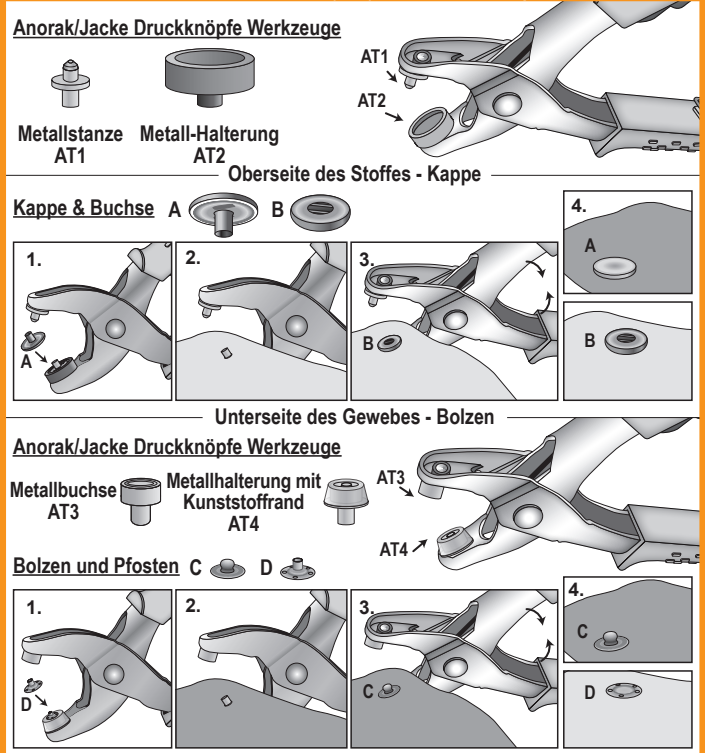

405 - Serie C: 15mm (5/8") Heavy Duty Druckknöpfe

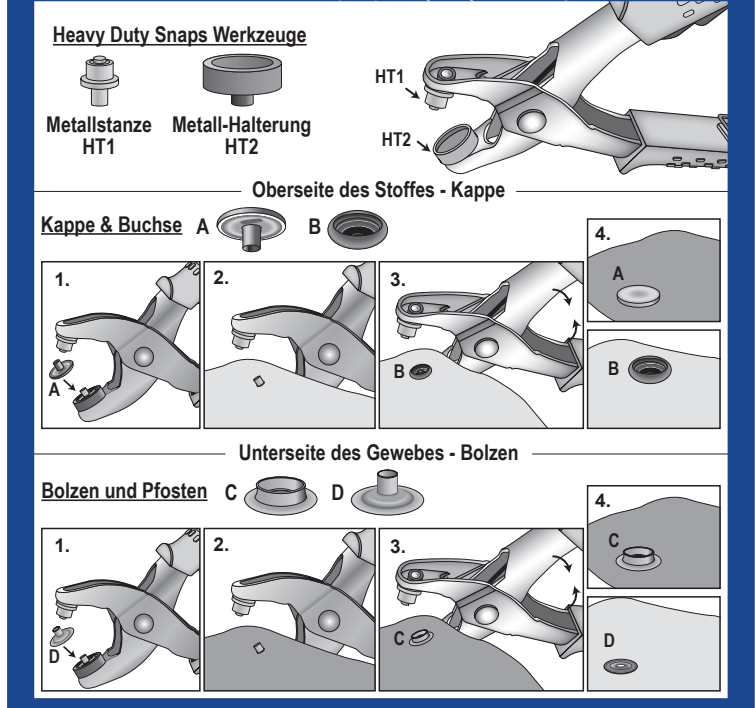

440 & 445 - Serie A: 11mm (1/2") Mode Druckknöpfe – Einfarbig & Jersey

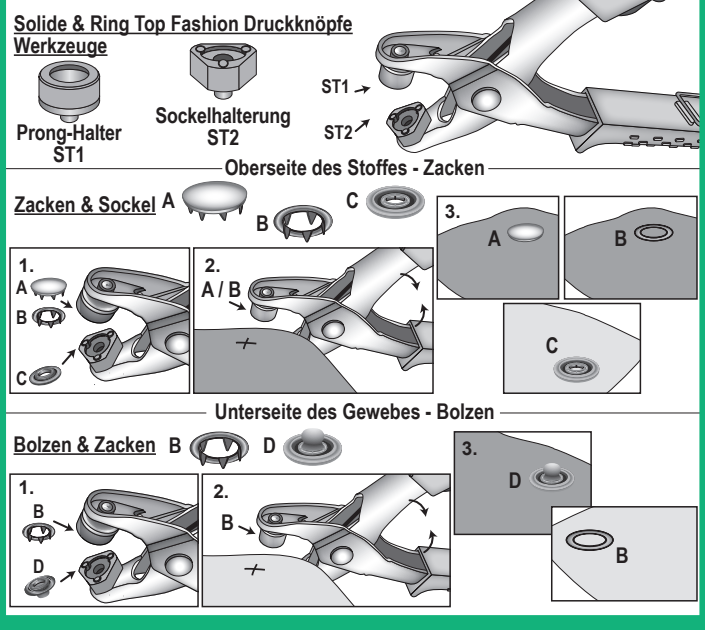

Serie 443: 12,4mm (1/2") Kunststoff-Druckknöpfe

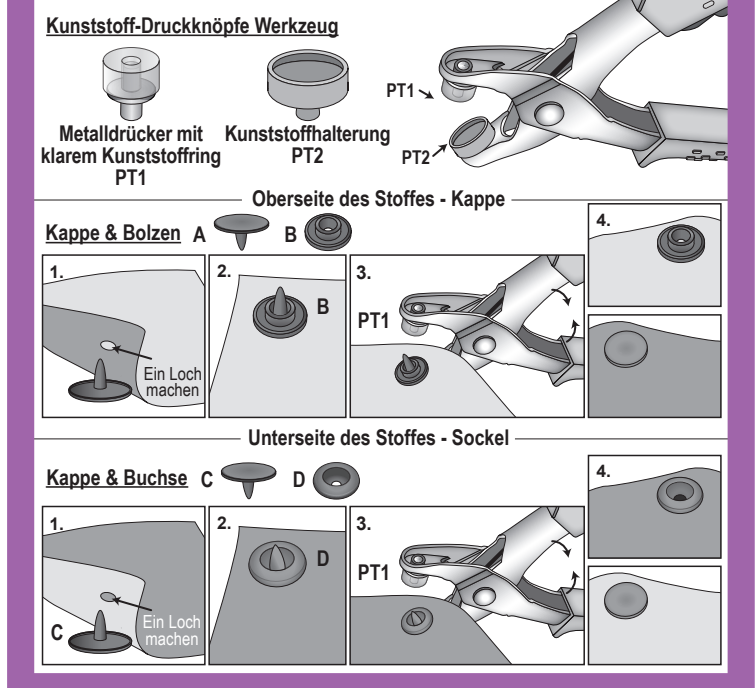

443 series: 12.4mm (1/2") Plastic Snaps | Boutons-pression en plastique | Broches de Broches de Plástico | Kunststoff-Druckknöpfe

#4431

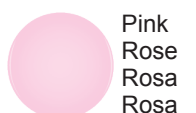
Aqua
Turquoise
Aqua
AquaBlack
Noir
Negro
SchwarzBlue
Bleu
Azul
BlauBronze
Bronze
Bronce
BronzeClear
Clair
Claro
TransparentCream
Crème
Crema
CremaGreen
Vert
Verde
GrünGrey
Gris
Gris
GrauLilac
Lilas
Lila
LilaNavy
Marine
Marino
NavyPink
Rose
Rosa
RosaPurple
Pourpre
Morado
ViolettRed
Rouge
Rojo
RotWhite
Blanc
Blanco
WeißYellow
Jaune
Amarillo
Gelb

440 & 445 - A Series: 11mm (1/2")

Solid & Ring Top Fashion Snaps | Boutons-pression - Couleur unie & Vetements legers | Broches a Presión - Tapa Superior & Anillo Superior | Mode Druckknöpfe - Einfarbig & Jersey



#440NR.BK

Black
Noir
Negro
Schwarz

#440NR.GD

Gold
Or
Oro
Gold

#440NR.PL

Pearl
Perle
Perla
Perlweiß

#445NR.BK

Black
Noir
Negro
Schwarz

#445NR.GD

Gold
Or
Oro
Gold

#440NR.SR

Silver
Argent
Plata
Silber

#440NR.WH

White
Blanc
Blanco
Weiß

#445NR.SR

Silver
Argent
Plata
Silber

#445NR.WH

White
Blanc
Blanco
Weiß

407 - B Series: 15mm (5/8")

Anorak/Jacket Snaps | Boutons-pression Anorak | Broches a Presión Anoraks y Chaquetas | Anorak Druckknöpfe



#407R.A

Antique Brass
Laiton
Latón antiguo
Messing

#407R.G

Gold
Or
Oro
Gold

#407R.B

Bronze
Bronze
Bronce
Bronze

#407R.N

Nickel
Nickel
Níquel
Nickel

435 Series: 4mm (5/32") Eyelets | Œillets | Ojates | Ösen



#435R.N

Nickel Silver
Nickel argent
Plata níquel
Neusilber

#435R.B

Black
Noir
Negro
Schwarz

#435R.G

Gold/Brass
Or/laiton
Oro/latón
Gold/Messing

405 - C Series: 15mm (5/8") Heavy Duty Snaps | Boutons-pression | Broches a Presión | Heavy Duty Druckknöpfe



#405R.A

Antique Brass
Laiton
Latón antiguo
Messing

#405R.G

Gold
Or
Oro
Gold

#405R.O

Black
Noir
Negro
Schwarz

#405R.B

Bronze
Bronze
Bronce
Bronze

#405R.N

Nickel
Nickel
Níquel
Nickel